



# RESILIENT Seated Gate Valve

[www.rdmultiples.com](http://www.rdmultiples.com)

The latest globally accepted concept in the waterworks Gate Valve technology is the Resilient seated type. With straight-through flow passage & fully rubber encapsulated gate, the valve combines the virtues like low pressure-drop, drop-tight seats & low operational torque. **R&D Multiple's Resilient seated Gate Valves** offer these & much more due to unique features, workmanship & quality. For any of your requirements, rely on this reliable & trustworthy valve for prolonged trouble-free service.

**R&D Multiples** introduces the **Resilient Seated Gate Valve (RSLV)** comparable with the best globally. The RSLV offers an unparalleled combination of features, workmanship, quality and cost-effectiveness. Endowed with selective top class design features, incorporating high precision tooling and manufacturing processes, RSLV is based on selection of best grades and quality of materials.

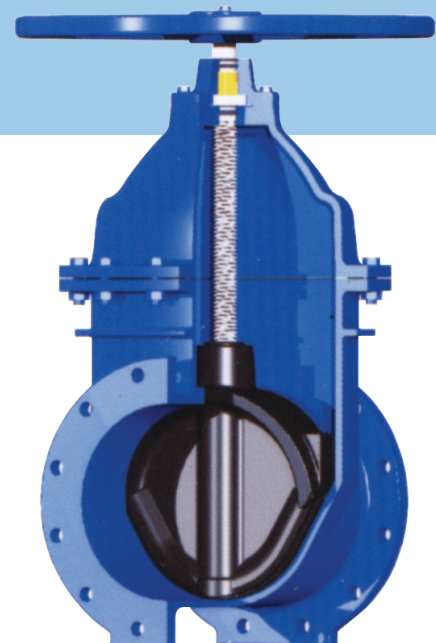

### Unique Characteristics:

Bubble-tight seats 🔴 Minimum pressure drop 🔴 Very low operating torque 🔴 Prolonged life 🔴 Straight through flow passage

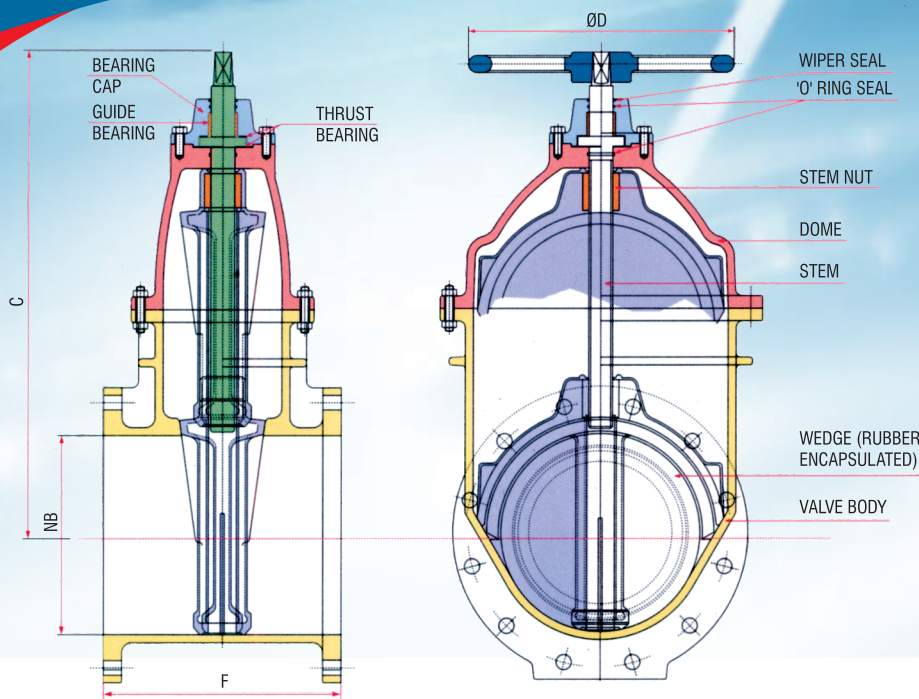

### Dimensions

Valve Size (in mm)	F (in mm)	C (in mm)	D Dia (in mm)
50mm	178	265	180
80mm	203	310	250
100mm	229	370	250
150mm	267	465	370
200mm	292	574	370
250mm	330	650	450
300mm	356	729	500
350mm	381	880	600
400mm	406	940*	*
450mm	432	1110*	*
500mm	457	1250*	*
600mm	508	1390*	*

### Materials of Construction

Body, Dome, Wedge Insert, Bearing Cap	Ductile Iron - IS 1865 Cast Iron - IS 210
Wedge	Nitrile / EPDM Vulcanized
Stem	Stainless Steel - AISI - 410/304/316
Stem Nut	Bronze - IS 318/320
Thrust Rings & Guide Bush	Teflon / Bronze
Gasket & Seals	Nitrile / EPDM rubber
Handwheel / Cap Top	Cast Iron IS 210
Fasteners	Stainless Steel / Plated Steel

### Notes :

1. Dimensions & Views are typical & may change without notice.
2. Dimensions: \*, C & D depend on drive selection.
3. Pressure Ratings: PN 1.0/ 1.6& 2.0MPa. Inquire for others.

### SPECIAL FEATURES:

- Completely rubber encapsulated wedge. No exposure of insert to the handled fluid.
- Double sealing surfaces ensuring perfect bubble-tight seats.
- Optimum contact between body seating and rubber sealing surfaces on wedge, leading to bubble-tight sealing at very low operating torque.
- Valve body seating surfaces are high quality smooth castings having smooth and tenacious epoxy coats. Results in low operating torque and long service life.
- Flow passage in valve body is unobstructed.
- Thrust on stem collar is taken by non-metallic thrust bearing discs.
- Stem guide provided by finely finished bearing bush
- Stem sealing free of gland packing, eliminating gland leaks and reducing gland friction torque substantially.
- Separate, self-aligning Stem-Nut provided which is possible to be replaced at site.
- Wide variety of materials for components, wide range of sizes and pressure ratings.
- Non Rising and Rising Stem constructions, with Handwheel/Cap, Flanged and Mechanical Joint ends, and accessories like Gearing (Spur/Bevel), Electrical Actuator, headstock and Position Indicator can be provided.
- Suitable for above ground and buried installations in Waterworks, Sewage, Effluent and Oil pipelines.



### R&D MULTIPLES (METAL-CAST) PVT. LTD.

Head Office : 106, United Industrial Estate, Mogul Lane,  
Mahim, Mumbai 400 016, Maharashtra, India.  
Tel : +91-22-4004 4425/26/27/28/29

Plant 1 : A-1/17, GIDC, Pardi - 396 125,  
District Valsad, Gujarat.

Plant 2 : Survey No. 304, Village Balda,  
Pardi - 396 125, District Valsad, Gujarat.

Engineering Division Office : C2-403, Saudamini Complex,  
Sri. No. 101/1, Bhusari Colony, Paud Road, Kothrud, Pune 411 038, India.

E-mail : mumbai@rdmultiples.com

Authorised Agent